

DESCRIPTION

Solenoid valve 2 way normally closed
 direct acting with dry armature.
 No metal parts in contact with the media.

CONSTRUCTION

Body	Acetal copolymer
Armature tube	Brass
Plunger and core	Stainless steel
Springs	Stainless steel
Seal material	SILICONE



2

FEATURES

Maximum allowable pressure 2bar
 Maximum fluid viscosity 25cSt (mm²/s)
 Ambient temperature: with class F coil -10°C +55°C
 with class H coil -10°C +80°C
 Preferred mounting position with vertical coil above

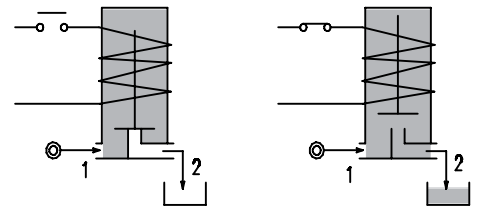
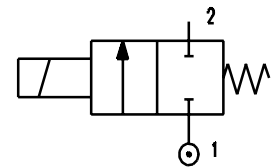

Version with closed vent

CODE ②	Connection G ISO 228	Orifice mm	Kv m ³ /h	Differential pressure bar			Nominal power			Coil		Seal ①	Temp. range °C
				Min	Max		AC Inrush	VA Holding	DC Watt	Series	Width		
					AC	DC							
E150PS75///...	-	7.5	0.7	0	0.2	0.2	12	8	6.5	3	22	SILICONE=S	<+95°C
E150PS75/6/...	1/4"			0	0.2	0.2							
D150PS75///...	-			0	-	0.2							
D150PS75/5/...	1/4"			0	-	0.2							

Version with open vent

CODE ②	Connection G ISO 228	Orifice mm	Kv m ³ /h	Differential pressure bar			Nominal power			Coil		Seal ①	Temp. range °C
				Min	Max		AC Inrush	VA Holding	DC Watt	Series	Width		
					AC	DC							
E150PS75/7/...	-	7.5	0.7	0	0.2	0.2	12	8	6.5	3	22	SILICONE=S	<+95°C
E150PS75/1/...	1/4"			0	0.2	0.2							
D150PS75/4/...	-			0	-	0.2							
D150PS75/3/...	1/4"			0	-	0.2							

② Coil

Example: E150PS75/6/30B G1/4" inlet - Closed vent
 Coil 24V 50/60Hz

COILS	Alternating Current 50/60Hz Volt							Direct Current Volt			Electrical connection	Connectors
	12	24	48	110	220 230	240	380	12	24	48		
Series 3 Width 22 Code ②	30A	30B	30C	30D	30E	30F	30G	300	301	302	DIN 46244	PG9 code 10348000

DESCRIPTION
 Class F insulation
 Voltage tolerance
 AC +15% -10%
 DC ± 10%
 Protection class
 IP65 with connector fitted
 IP00 without connector
 Continuous service ED100%

OPTIONS
 Class H insulation
 Cable attached
 Special coil voltage
 Special coil powers

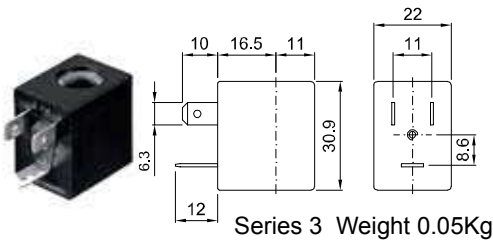

Series 3 Weight 0.05Kg

SPARE PARTS LIST

1. Coil fixing nut
2. Coil
3. Diaphragm

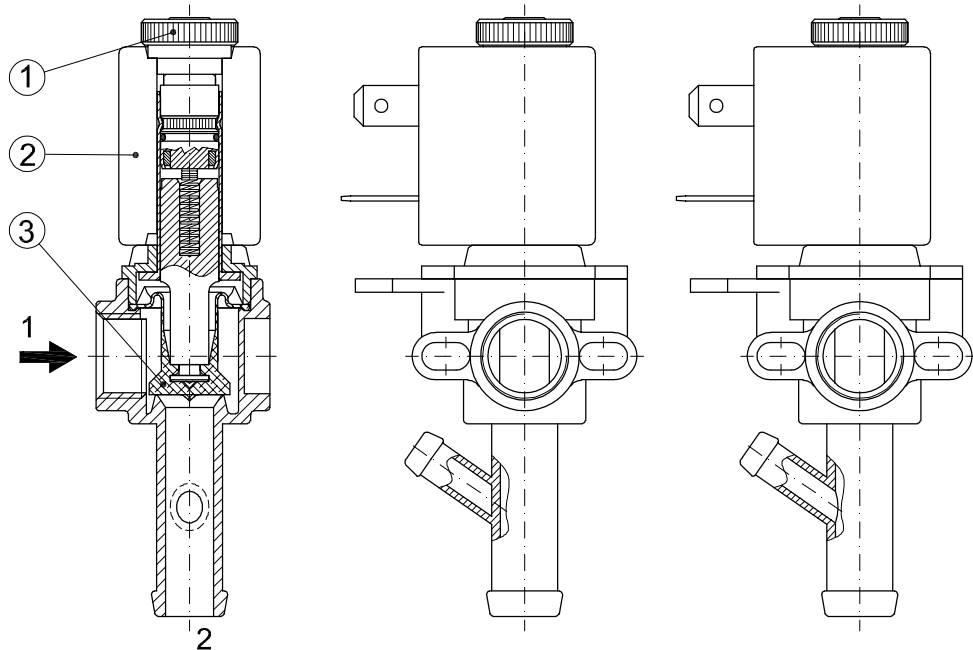

OVERALL DIMENSION

